

OTIS

GEN2™ Lux



THE WAY TO GREEN™



GeN2™ Lux

THE WAY TO GREEN

CONVENTIONAL STEEL ROPES



1 FLEXIBLE COATED STEEL BELTS

CONVENTIONAL INSPECTION OF STEEL ROPES

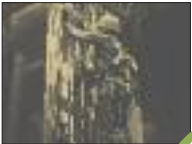

2 PULSE™ BELT MONITORING SYSTEM

CONVENTIONAL MACHINE



3 COMPACT GEARLESS MACHINE

CONVENTIONAL DRIVE



4 REGEN™ VF DRIVE

CONVENTIONAL GUIDE SHOES



5 LOW FRICTION ROLLERS

CONVENTIONAL LIGHTING

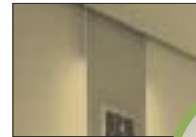

6 LED LIGHTING

CONVENTIONAL DISPATCHING SYSTEMS

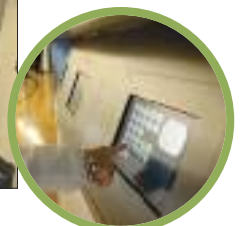

7 COMPASS™ DESTINATION ENTRY SYSTEM

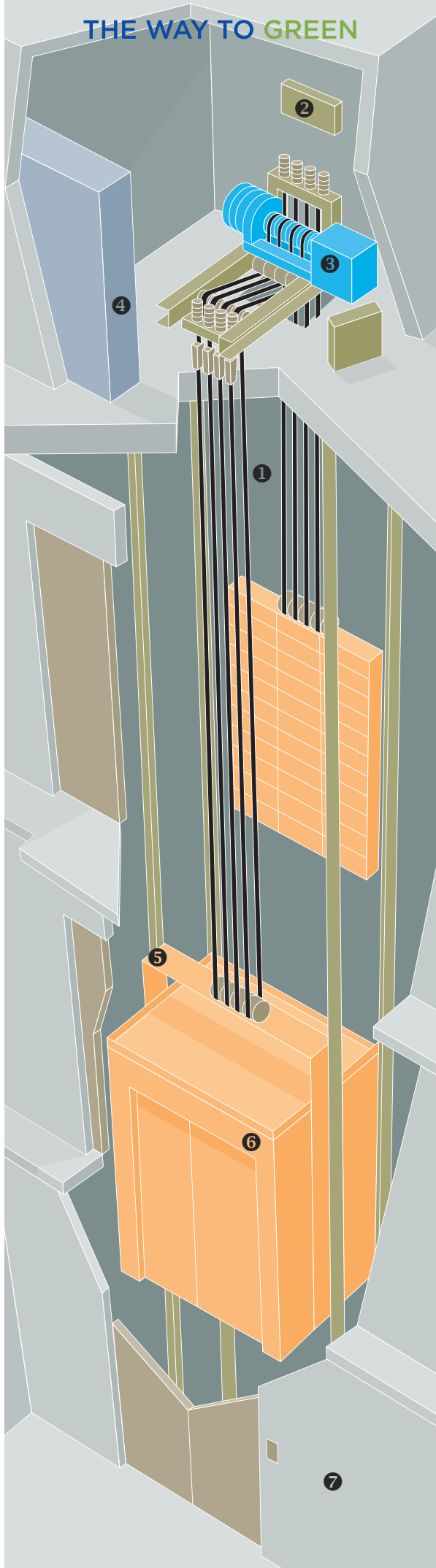

The coated steel reinforced belt: technology that has transformed an industry.

The environmentally-friendly GeN2 system establishes new standards for lift performance, reliability and design flexibility. And while offering passengers more comfort, it also achieves both cost and energy savings.

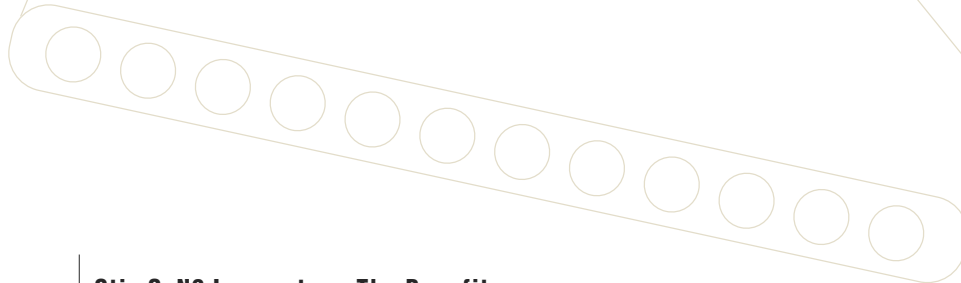

Otis GeN2 Lux system: The Benefits

An innovative lift system which provides:

Environmental protection

- The belts and gearless machine with sealed-for-life bearings do not require any form of polluting lubricant.
- A compact gearless machine together with an energy-conserving ReGen drive achieves energy savings of up to 75% compared to a conventional system with a non-regenerative drive. It also reduces operational costs.

Enhanced ride quality

- Replacing conventional steel ropes with smooth, polyurethane-coated steel belts results in a quieter and smoother ride.
- A gearless machine controlled by a closed-loop ReGen drive provides a comfortable ride with outstanding stopping accuracy.
- Faster and smoother lift acceleration and deceleration with advance opening and closing of the doors means more efficient passenger handling.

Safety and reliability

- The PULSE™ system continually monitors the status of the belt's steel cords so enhancing both their lifetime and their reliability.
- With the optional Elite service, customers enjoy a priority service that radically improves both lift reliability and passenger reassurance. The level of service goes far beyond conventional maintenance to offer an array of benefits from rapid and efficient repairs to customizable lift operations.

The GeN2 Lux system is the smart choice for 'green' buildings.

REGEN DRIVE

A typical lift includes three major components: the machine, the lift car and the counterweight. The counterweight is designed to balance a half-loaded car. Electrical power is generated when a heavily-loaded car travels in a 'down' direction or a lightly-loaded car travels in an 'up' direction (green area of graph).

With a non-regenerative drive the energy generated is dissipated in a set of resistors creating a waste-heat load in the building.

With a regenerative drive, the energy generated is fed back into the building's grid where it can be used by other loads connected to the same network. The energy consumed with a non-regenerative drive is represented by the yellow area while with a regenerative drive the energy consumed is just the difference between the yellow and green areas.

The amount of energy savings due to regeneration depends on various system parameters and configurations such as car load, speed, length of run, traffic pattern and system efficiency.



ReGen drive

As the preferred choice for 'green' building initiatives, ReGen drives deliver substantial energy savings while helping to meet or exceed established worldwide standards.

- Energy savings (up to 75%)
- Low harmonic distortion (typically below 5%) and reduced Radio Frequency Interference
- Operational cost savings through reduced peak power demand and decreased energy consumption
- Optimal performance - the drive operates with voltage fluctuations of up to 30%.

Electrical power generation



Heavily-loaded car in down direction

Lightly-loaded car in up direction

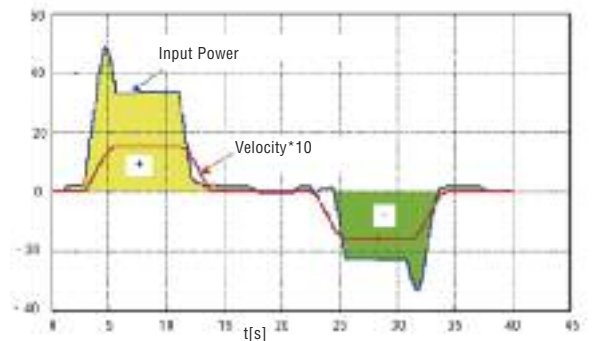

● Energy consumed with fully-loaded car in 'up' direction.

● Energy generated with fully-loaded car in 'down' direction.

It protects the environment....

A 'GREEN' MACHINE

Neither the belts nor the gearless machine with sealed-for-life bearings require any form of polluting lubricants.

The low inertia gearless machine is equipped with a highly efficient PM synchronous motor of radial construction.

The result is a machine which is up to:

- 50% more efficient than conventional geared machines.
- 10% more efficient than conventional gearless machines with induction asynchronous motors.
- 15% more efficient than other machines with PM motors of axial construction design.



Gearless machine with sealed-for-life bearings and maintenance-free brake disc.

ENERGY EFFICIENCY

Comparison vs conventional lifts: Propulsion system

1600 kg at 2,5 m/s,
15 stops,
300 000 starts/yr

Peak power demand (kVA)

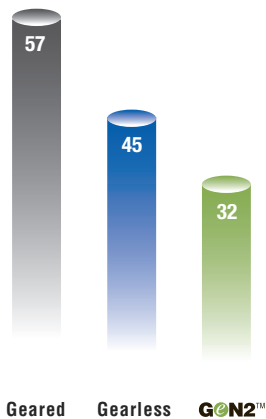

Energy consumption (kWh)

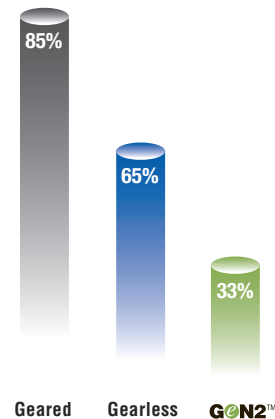

Running the whole length of the car operating panel, LED lighting also achieves important energy savings.

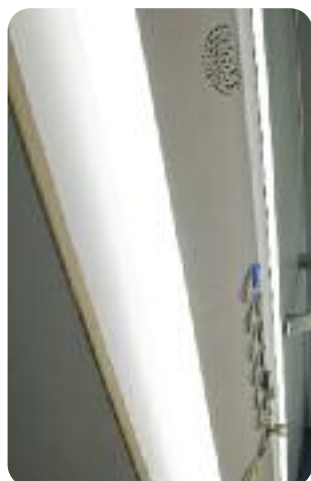

ENERGY-EFFICIENT LED LIGHTING

Superior quality with a longer life

Up to ten times longer lasting than a conventional fluorescent source, LED lighting is fitted as standard on the GeN2 Lux system. Besides saving costs, a lift has to be taken out of service far less frequently for maintenance visits which in turn reduces downtime.

Importantly, also, an automatic switch-off mode offers up to 80% energy savings over a fluorescent source. And repeated switching on and off does not affect its lifetime. Finally, light quality, too, is improved as LED lighting experiences none of the flickering associated with a fluorescent source.

....and it achieves substantial energy savings.

VDI 4707 CLASSIFICATION

A standard established in 2009 by Verein Deutscher Ingenieure, the authoritative association of German engineers, VDI 4707 assesses the energy performance of lifts taking into account load, speed, frequency of use and travel height - both during travel and standby modes.

The energy demand of a lift is rated using seven different classes from A to G where A reflects the highest rating possible (the least energy used) and G the lowest (the most energy used).

Measurements taken on installations with standard configurations prove that the GeN2 Lux lifts have earned a Class A rating so achieving the very highest energy efficiency criteria.

Note: "Usage category" shown on the table is calculated based on typical average number of travels per year and average travel time (from REM™ system database) for each GeN2 Lux duty.

	GeN2 Lux
Load (kg)	1600
Speed (m/s)	2.5
Number of stops	15
Rise (m)	45
Trips per year	300 000
Travel time (hrs/day)	3.0
Usage category	4
Travel class	A
Standby class	C
Efficiency class	A

Energy efficiency class



REDUCED ENERGY CONSUMPTION

The standard GeN2 system incorporates a highly efficient machine, an energy-conserving ReGen drive and LED lighting with an automatic switch-off function to significantly reduce overall consumption.

1600 kg at 2.5 m/s
15 stops
45 m rise
300 000 starts/yr
(Usage category 4)

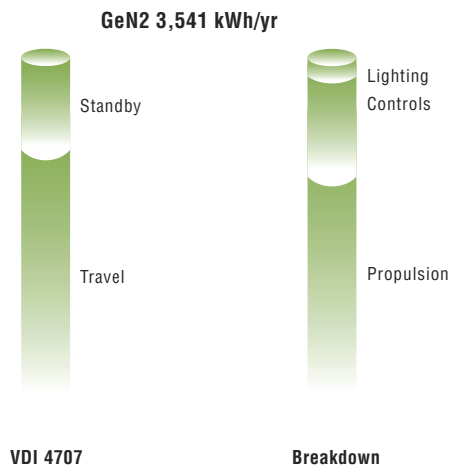

Values shown for standard GeN2 system. Technology advances will result in further reductions of energy consumption.

GEN2 TECHNOLOGY - THE WAY TO GREEN

	Flat Belt	Pulse	Machine	ReGen Drive	Rollers	LED Lighting	Compass
GeN2™ The benefits							
Energy Savings	★		★	★	★	★	★
Environmental Protection	★	★	★	★	★	★	★
Ride Comfort	★		★	★	★		
Safety and Reliability	★	★	★	★	★	★	★

At the same time it achieves an outstanding level of ride quality.

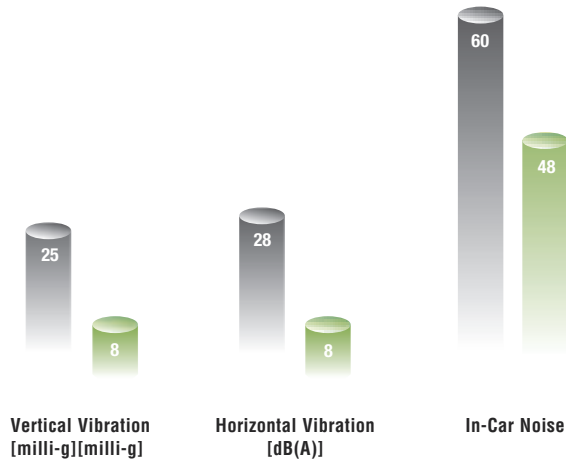

- Industry geared system
- GeN2 Premier system

A gearless machine with a closed-loop VF drive increases passenger comfort.

The gearless machine combined with a sophisticated load weighing device and a closed loop variable frequency drive with vector control contribute to a smooth and quiet ride. Furthermore, they result in outstanding stopping accuracy of within +/- 3mm at every landing.



The low friction rollers eliminate the need for lubrication of the rails and at the same time enhance ride quality.

EXCEPTIONAL RIDE QUALITY

Replacing metal ropes with smooth, flat belts means a quieter and smoother ride.

Enhanced ride quality is achieved through the combination of a number of factors. Otis' flat polyurethane-coated steel belt which eliminates the metal-to-metal effect of conventional ropes results in quiet operation. The rollers also contribute to ride quality as does the gearless machine combined with a closed-loop variable frequency ReGen drive with vector control. The latter also assures outstanding stopping accuracy (within +/- 3 mm at every landing).



Interaction of Otis' flat belt and the smooth crowned sheave.

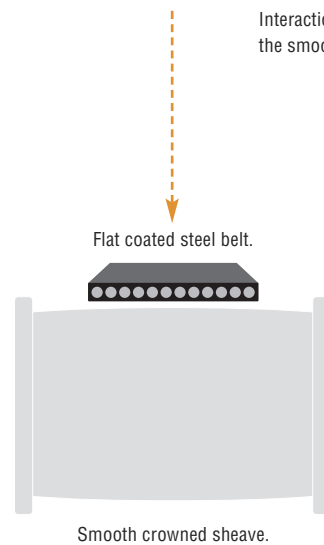

The GeN2 Lux lift offers exceptional levels of performance.

FASTER OPERATION

With adjustable acceleration and deceleration rates, up to $0,8 \text{ m/s}^2$, the GeN2 Lux lift rapidly reaches its nominal speed and furthermore decelerates and stops both smoothly and quickly.

An intelligent door operating system with advance door opening minimises the time for passenger entering and exit and so enhances traffic flow.

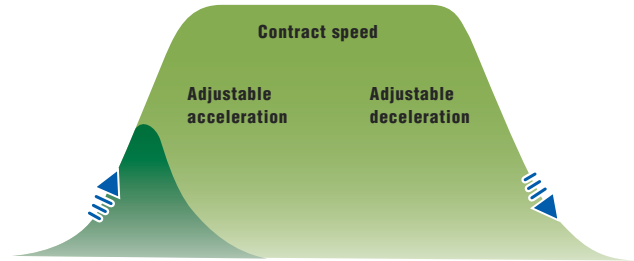

- Short run
- Long run

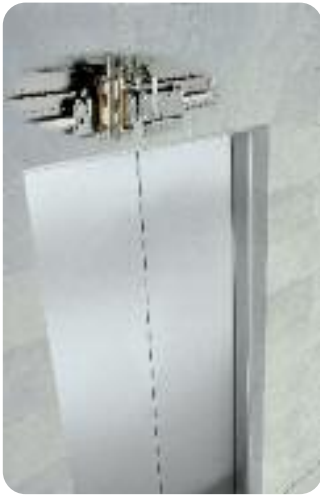

HIGHER RISES, INCREASED SPEEDS

With the Gen2 Lux system, a range of speeds is available from 1.0 m/s to 2.5 m/s and these speeds serve rises from 45 m to 120 m.



MORE FLEXIBLE DESIGN

With the cars of the Gen2 Lux system, it is possible to use up to 50% of the duty loads for customised decoration. Importantly, too, the dimensions of the car together with both the door opening width and height are flexible so accommodating varying customer requirements.

While advanced security features demonstrate an absolute commitment to both safety and reliability.

SAFETY FEATURES

For lift users and service technicians.

- **Door Deterrent Device**

If the car is stopped between floors, a deterrent device prevents the car door from opening. Hence a person cannot take the risk of exiting.

- **Hoistway Access Detection**

To protect a person entering the hoistway, a special safety feature prevents the lift from operating after a landing door has been opened.

- **Rescue System**

A patented, battery-operated rescue system with electronic speed monitoring enables the safe and fast rescue of trapped passengers in the event of a power failure.

- **LAMBDA™ Entrance Protection**

A screen of infrared beams acts as an invisible safety curtain. When an obstacle breaks this screen, the sensitive LAMBDA 2D or LAMBDA 3D system detects it and immediately reopens the doors.

- **Stopping Accuracy**

The belt's reduced stretch compared to conventional steel ropes together with a closed loop VF control results in outstanding stopping accuracy (within +/-3 mm at every landing).

- **Machine Brake System**

To further improve safety, the machine's dual brake system is equipped with two switches to prevent the lift from moving before the brake is fully released.

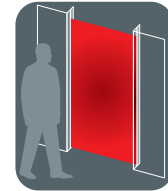
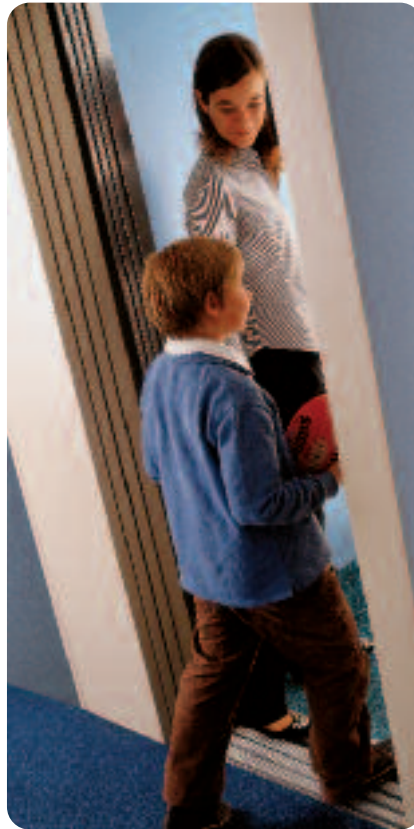

LAMBDA 2D entrance protection.



LAMBDA 3D (optional)



Stopping accuracy: to within +/- 3 mm.



INCREASED RELIABILITY

The PULSE electronic system monitors the status and integrity of the belt's steel cords 24/7d providing advance notice of the need for replacement. Not only does this improve their reliability and extend their life but it also reduces the downtime required for inspection.

An extensive range of car designs provides solutions to differing aesthetic needs...

OPTIMA™

The Optima car perfectly illustrates the principle that elegance can be achieved through simplicity – provided it's based on an inspired idea. With the Optima design, that idea is embodied by the energy-efficient LED car operating panel actually illuminating the car. Important to the car's refined appearance are the panels themselves. In three finishes, they are cheering to the eye and easy to maintain. In fact it is the balance between the aesthetic and the practical that defines the Optima car.



SKINPLATE



LAMINATE



STAINLESS STEEL



SELECTA™

The name unequivocally defines the design. The Selecta car is about choice. Again illuminated by the LED car operating panel, it satisfies the most diverse requirements. There are five car wall designs, various flooring types together with different car operating panel designs and handrail types. With endless possibilities, the Selecta car has, effectively, been conceived by us to be designed by you.



SKINPLATE



LAMINATE



STAINLESS STEEL



WOOD



GLASS

...while LED lighting achieves valuable energy savings.

LUMINA™

The Lumina car is distinguished by its range of ceiling lighting arrangements. Each offers a different level of LED illumination, from the discreet to the sumptuous, and in combination with a choice of four wall types, a host of decorative effects can be achieved. Painsstaking attention to detail can also be found in the quality of the car fittings. Cumulatively they, too, help establish the prestige of the Lumina car.



SKINPLATE



LAMINATE



WOOD



STAINLESS STEEL



PANORAMA™

A novel and exciting way to travel in a commercial or residential complex, the attraction of the Panorama lift is that it is both designed to offer passengers a view and the public a focal viewpoint. Adding the drama of movement to an architectural concept, the Panorama lift is increasingly chosen for installation in a lobby or atrium. The glass panels are available in clear or smoked glass and the frames around them in white skinplate, one of three stainless steel finishes or prime-coated steel ready for finishing on site. The lift can be adapted to any number of architectural and decorative specifications.

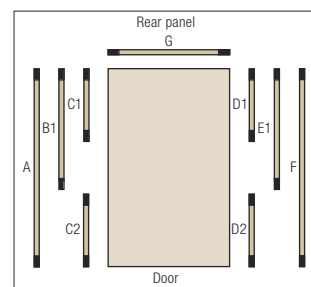

Glass panel arrangements

The Compass™ system enhances lift efficiency and reduces both waiting time and travel time.

COMPASS DESTINATION MANAGEMENT

The strength of the optional Compass system is that it offers passengers an efficient and personalised service at the same time as improving system performance.

Unlike conventional dispatching, the Compass system helps avoid congestion and transports passengers to their desired floor with less waiting time and fewer stops.

Passengers input their destination with keycards or, manually, using touchscreens and keypads strategically placed in the lobby.

The system instantly directs them to designated cars with each passenger knowing which car to take - so moving directly to the appropriate car location.

Knowing the right car to enter helps avoid confusion and passengers automatically rushing to the next car that arrives. Hence it enhances traffic flow immeasurably.

Passengers travelling to adjacent floors are assigned the same car. This, too, significantly reduces travel time by limiting the number of stops per trip.



STEP 1

Enter your floor destination

The Compass system instantly assigns you to a lift designated for your requested floor.



STEP 2

Proceed to your assigned lift

As you are heading to your assigned lift, the car is already on its way to collect you.



STEP 3

Enter your assigned car

Inside the lift, an illuminated floor button confirms your destination.



STEP 4

Travel to your designated floor

The Compass system reduces your travel time and provides a more comfortable ride - with fewer people per car and fewer stops per trip.

Service and quality assurance are cornerstones of our customer-oriented focus.



Service initiatives that have become industry benchmarks.

How efficiently a lift performs depends on how well a lift is maintained. To this end, Otis offers an unrivalled range of maintenance solutions which can be adjusted to meet the very specific demands of each installation. Hence each solution is cost-effective and designed to assure equipment longevity.

Critical to Otis' comprehensive support system is Otisline - a dedicated in-house call centre where highly trained professionals are at your service 24/7 to resolve an issue promptly and efficiently.

Important, too, is communication. Vital to our client-oriented strategy, it means that through eService - our 24/7 online internet access - you will have immediate access to your lift's performance and service data. The result is increased transparency and accountability.

Finally we should mention quality. Stringent quality control procedures, ongoing and in-depth training of our engineers and the use of documented standard practices means the quality of both our products and our services is unsurpassed.

The incomparable advantages of Elite service.

Designed as a priority service for Otis customers, Elite service delivers an unparalleled level of both response and reliability that totally transforms the performance of your lifts.

The result of pioneering research into remote technology, Elite service involves a team of specialist engineers dedicating themselves to the monitoring and maintenance of your lifts.

Using advanced diagnostics, they can connect to your unit, identify an anomaly and frequently be able to correct the fault almost immediately.

What's more, because they can pinpoint the source of the problem, they can remove the risk of its recurrence.

Being able to anticipate problems, react and repair them quickly dramatically reduces downtime. And being able to restore a lift to service quickly means that in the unlikely event of a service interruption, the lift will normally be up and running again within minutes - enormously reassuring should a passenger be in the lift.

Gen2 Lux Specifications

Load capacity (kg)	800	1000	1275	1600					
Passenger capacity	10	13	17	21					
Car dimensions (mm)	Width	1350	1100	1600	1200	2000	1400	2100	2000
	Depth	1400	2100	1400	2300	1400	2400	1600	1700
Speed	2.0 m/s - 2.5 m/s								
Maximum rise	up to 150 meters								
Maximum number of stops	up to 32 stops								
Machine	Gearless with permanent magnets synchronous motor								
Drive	ReGen drive with closed-loop vector control								
Cars in a group	up to 8								
Door opening width (mm)	Telescopic		800-1000		1000-1100		1200-1300		
	Centre Opening	800-900		900-1100		1100		1100	1100
Door opening height (mm)	2000-2300								
Car entrances	1 or 2 (opposite)								
Power (3 phases + neutral)	400 volts (+ - 10%)								
Frequency	50 or 60 Hz								

Please consult Otis for other available combinations

www.otis.com

Otis reserves the right to change any part of this specification without prior notice.

Printed on PEFC 100% paper Cert. No PEFC/10-31-1232

